

**Spindle Components**

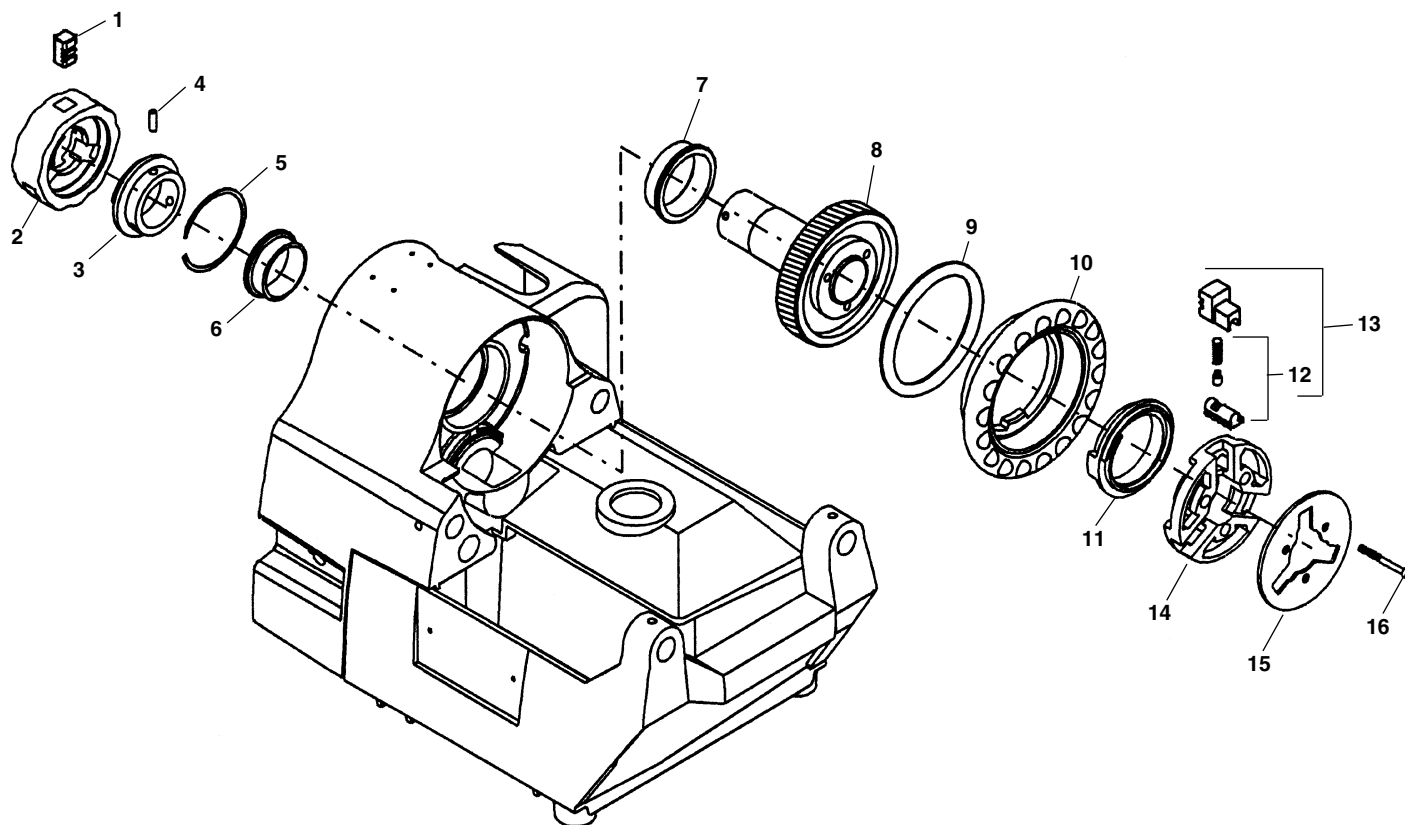

**NOTE: Order parts by Catalog Number only.  
DO NOT order by Reference Number.**

<u>Ref. No.</u>	<u>Catalog No.</u>	<u>Description</u>	<u>Ref. No.</u>	<u>Catalog No.</u>	<u>Description</u>
1	69447	Centering Jaw Set	9	69297	Spacer Ring
2	69307	Centering Head	10	69202	Hand Wheel
3	69312	Centering Scroll	11	69197	Scroll
4	54007	Roll Pin 1/4" x 3/8" (3)	12	69412	Jaw Insert Set
5	69317	Retaining Ring	13	69237	Chuck Jaw Set
6	10968	Rear Spindle Bearing	14	69262	Chuck Cap
7	10963	Front Spindle Bearing	15	69267	Chip Plate
8	69272	Drive Shaft	16	46035	Screw 5/16" - 18 x 1 3/4" Soc. Hd. (3)

Drive Components

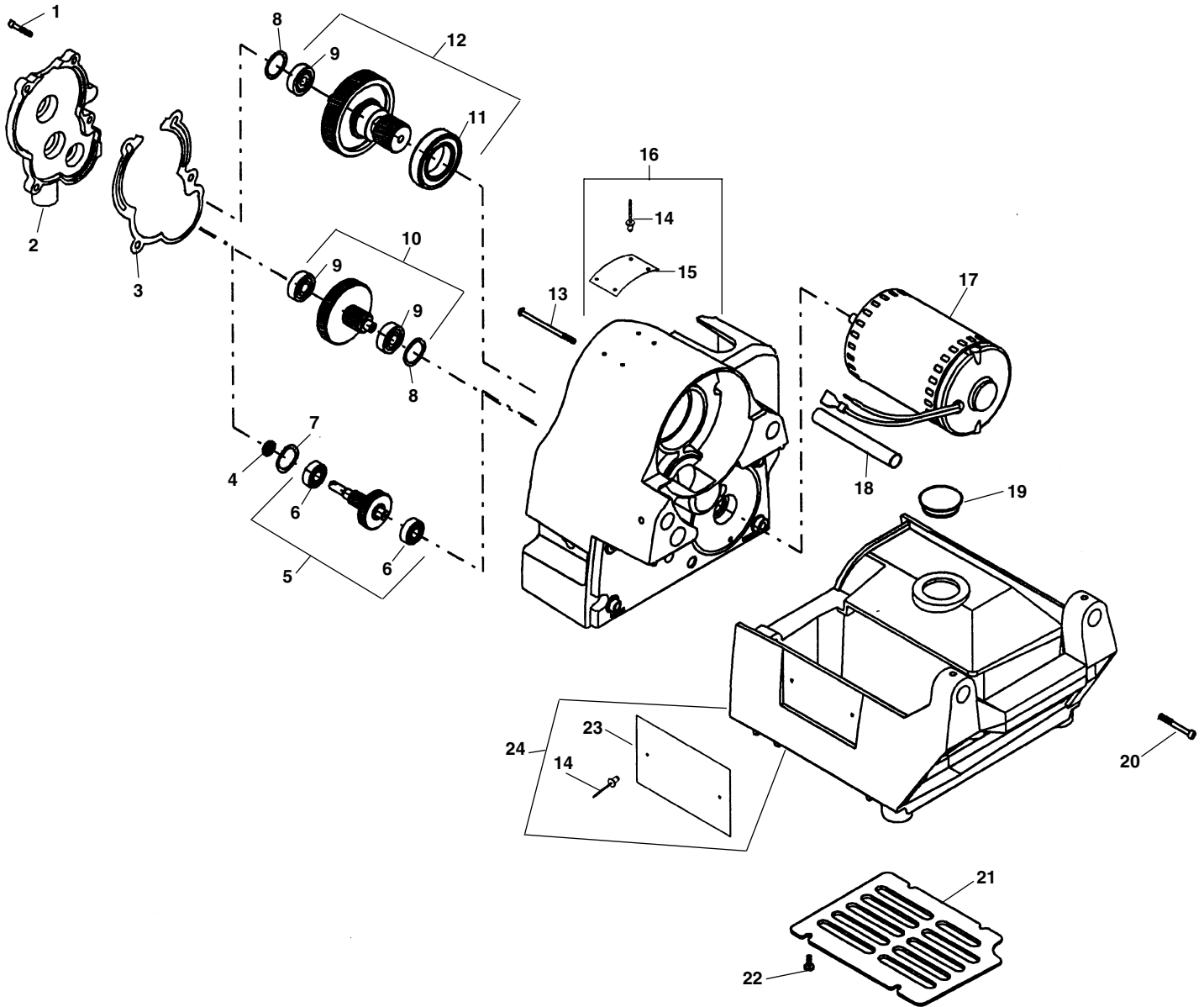

**NOTE: Order parts by Catalog Number only.  
DO NOT order by Reference Number.**

Ref. No.	Catalog No.	Description	Ref. No.	Catalog No.	Description
1	40910	Screw 1/4" - 20 x 1/2" Soc. Hd. (4)	13	69402	Screw #10 - 32 x 4" Pan Head (2)
2	69362	Gear Case Cover	14	85920	Pop Rivet 3/32" (6)
3	69332	Gear Case Gasket	15	69347	Warning Plate
4	96880	Seal	16	69227	Spindle Housing w/Spindle Bearings
5	69207	1st Intermediate Gear Assembly	17	69222	Motor 115V
6	59147	Ball Bearing (2)	18	59342	Insulator Sleeve
7	35365	Wave Spring	19	69367	Brush Cover Plastic Plug
8	68037	Wave Spring	20	40657	Screw 1/4" - 20 x 1 1/2" Soc. Hd. (4)
9	44760	Ball Bearing (3)	21	69252	Motor Cover
10	69212	2nd Intermediate Gear Assembly	22	79965	Screw #10 - 32 x 1/2" Pan Head (4)
11	69277	Ball Bearing	23	69387	Name Plate
12	69217	Main Drive Gear Assembly	24	69242	Base

**Coolant System Components**

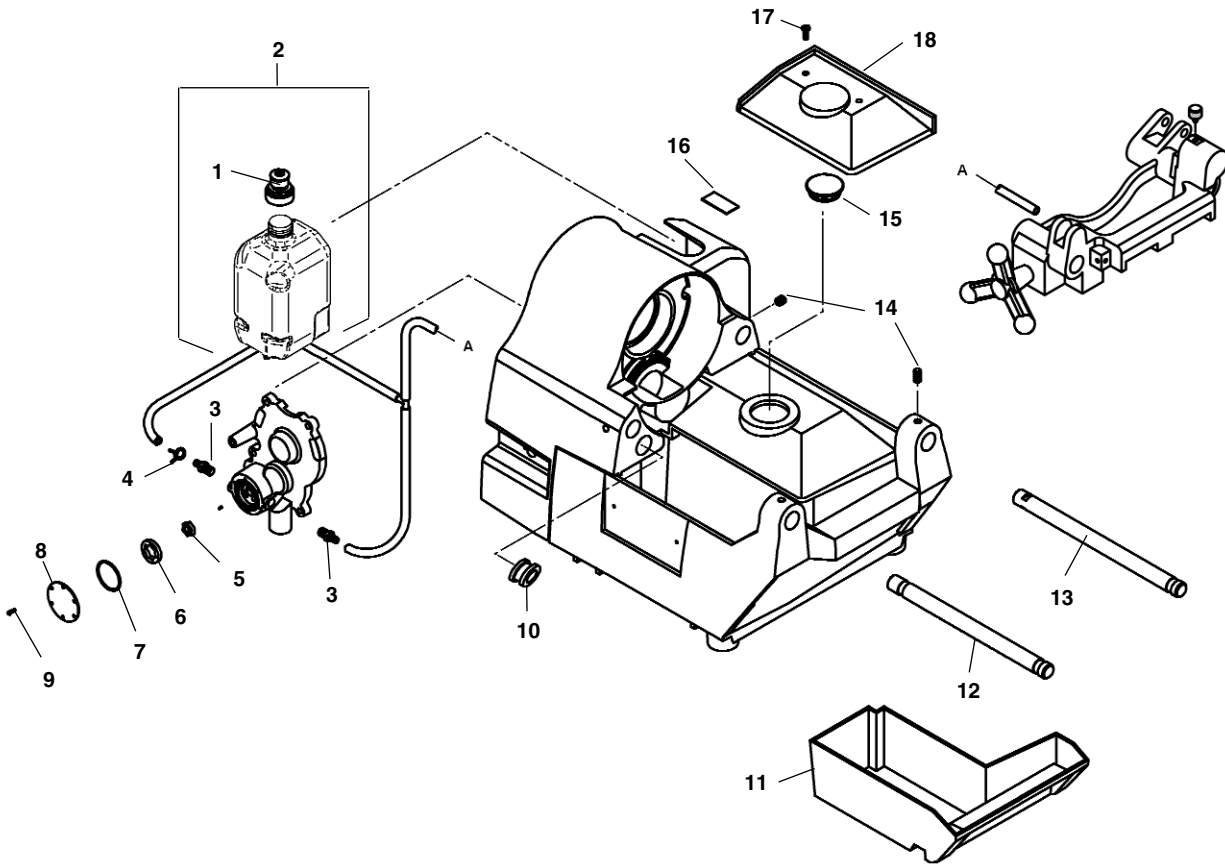

**NOTE: Order parts by Catalog Number only.  
DO NOT order by Reference Number.**

<u>Ref. No.</u>	<u>Catalog No.</u>	<u>Description</u>	<u>Ref. No.</u>	<u>Catalog No.</u>	<u>Description</u>
1	69452	Reservoir Cap	11	69257	Chip Tray
2	94707	Coolant Reservoir Assy w/Hoses	12	69322	Front Rail
3	69157	Hose Fitting 1/8" NPT x 1/4" Barb (2)	13	69247	Rear Rail
4	72457	Hose Clamp	14	69397	Set Screw 1/4" - 20 x 5/16" (4)
5	96885	Gerotor Pin	15	69367	Brush Cover Plastic Plug
6	96870	Gerotor Set	16	72387	Vent Cap Decal
7	96875	O-Ring		72392	Vent Cap Decal (Europe, Japan)
8	96840	Cover Plate	17	79965	Screw #10 - 32 x 1/2" (2)
9	46130	Screw #4-28 Self Forming (6)	18	72027	Drip Cover
10	47080	Grommet			

**Carriage Components – Type 2**

**NOTE: Order parts by Catalog Number only.  
DO NOT order by Reference Number.**

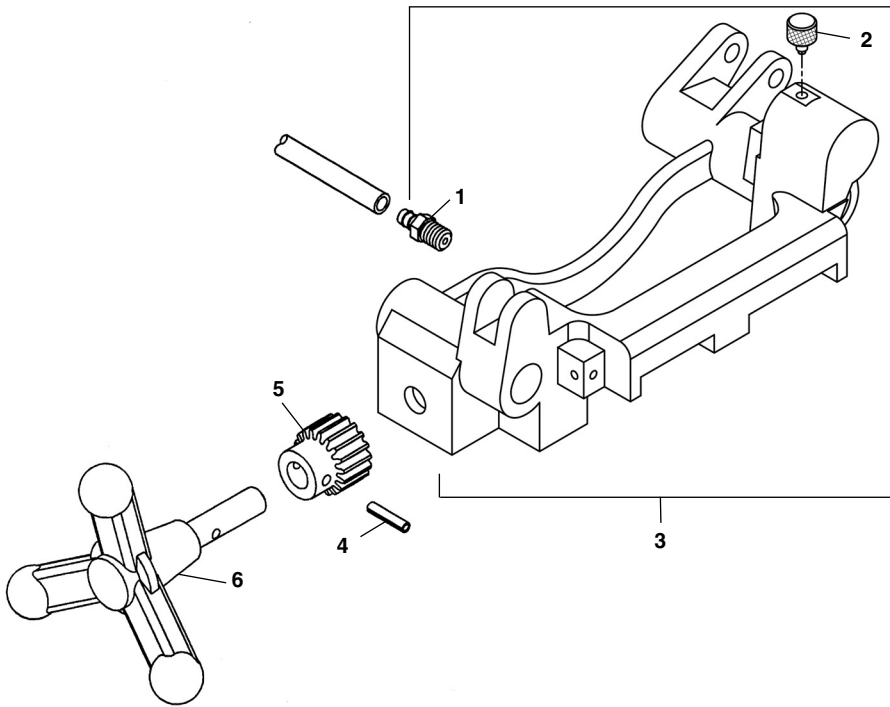

Ref. No.	Catalog No.	Description
1	69157	Hose Fitting 1/8" NPT x 1/4" Barb
2	30763	Retainer, Die Head
3	69142	Carriage Assembly
4	34342	Roll Pin 3/16" x 15/16"
5	59092	Pinion
6	69147	Hand Wheel

**610 Die Head – Type 2**

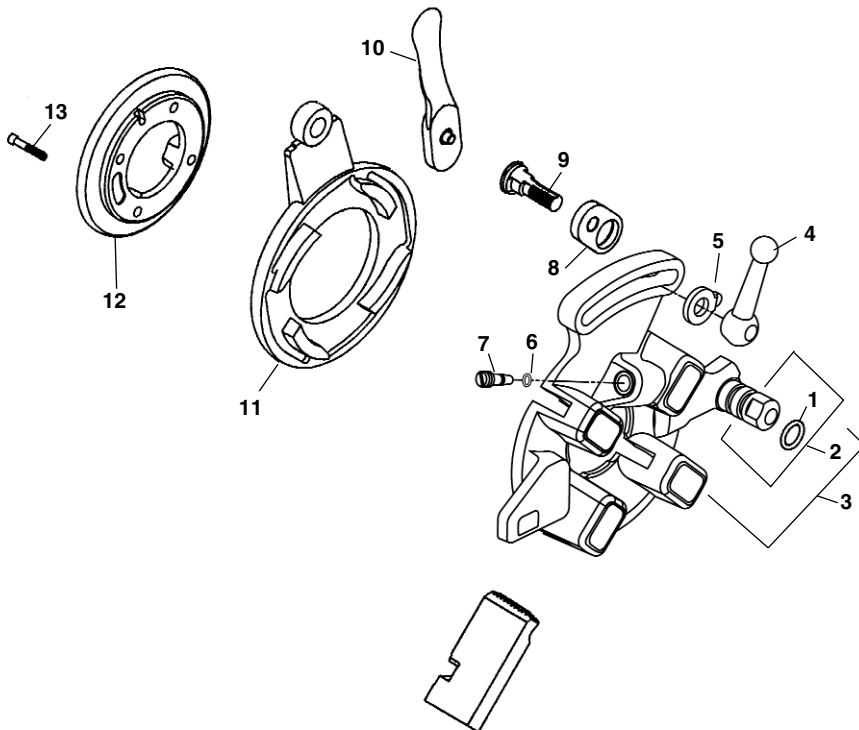

Ref. No.	Catalog No.	Description
—	67817	610 Die Head
1	69392	O-Ring
2	69292	Post
3	69302	Die Head Body w/Post & O-Ring
4	39970	Clamp Lever
5	26957	Washer
6	69182	O-Ring
7	69177	Needle Pin
8	39950	Throwout Link
9	39860	Lock Screw
10	46555	Throwout Lever
11	69442	Cam Plate
12	69352	Retaining Ring
13	32205	Screw 1/4" - 20 x 5/8" Socket Head (4)

**354 Cutter**

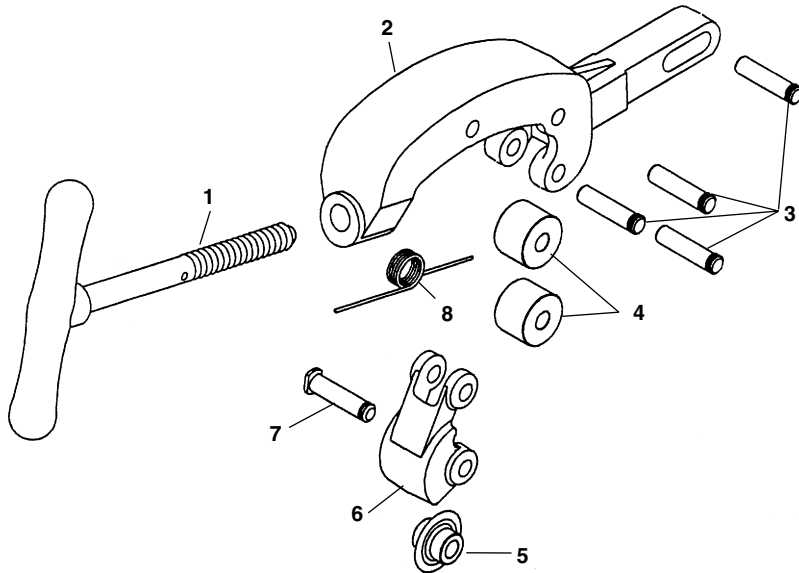

**NOTE: Order parts by Catalog Number only.  
DO NOT order by Reference Number.**

Ref. No.	Catalog No.	Description
—	68877	354 Cutter Assembly
1	69007	Feedscrew & Handle
2	69017	Cutter Frame
3	46662	Roller Pin (4)
4	34775	Roll (2)
5	33105	F3 Cutter Wheel
6	69012	Wheel Housing
7	34780	Pin & Clip
8	58617	Torsion Spring

**334 Reamer**

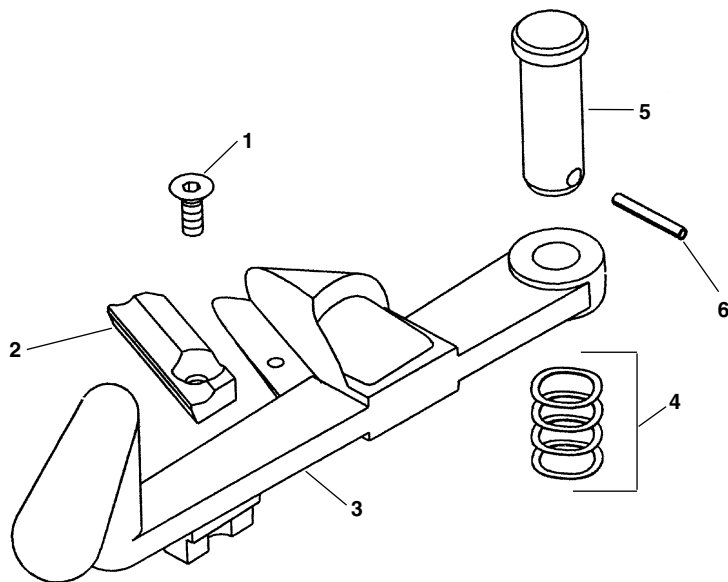

Ref. No.	Catalog No.	Description
—	68872	334 Reamer Assembly
1	68997	Screw #8-32 x 7/16" Flat Head
2	68977	Reamer Blade
3	68992	Reamer Arm w/Cone
4	87940	Wave Washer
5	68987	Clevis Pin
6	69002	3/32" x 3/4" Roll Pin

Electrical Components – 120V 60Hz

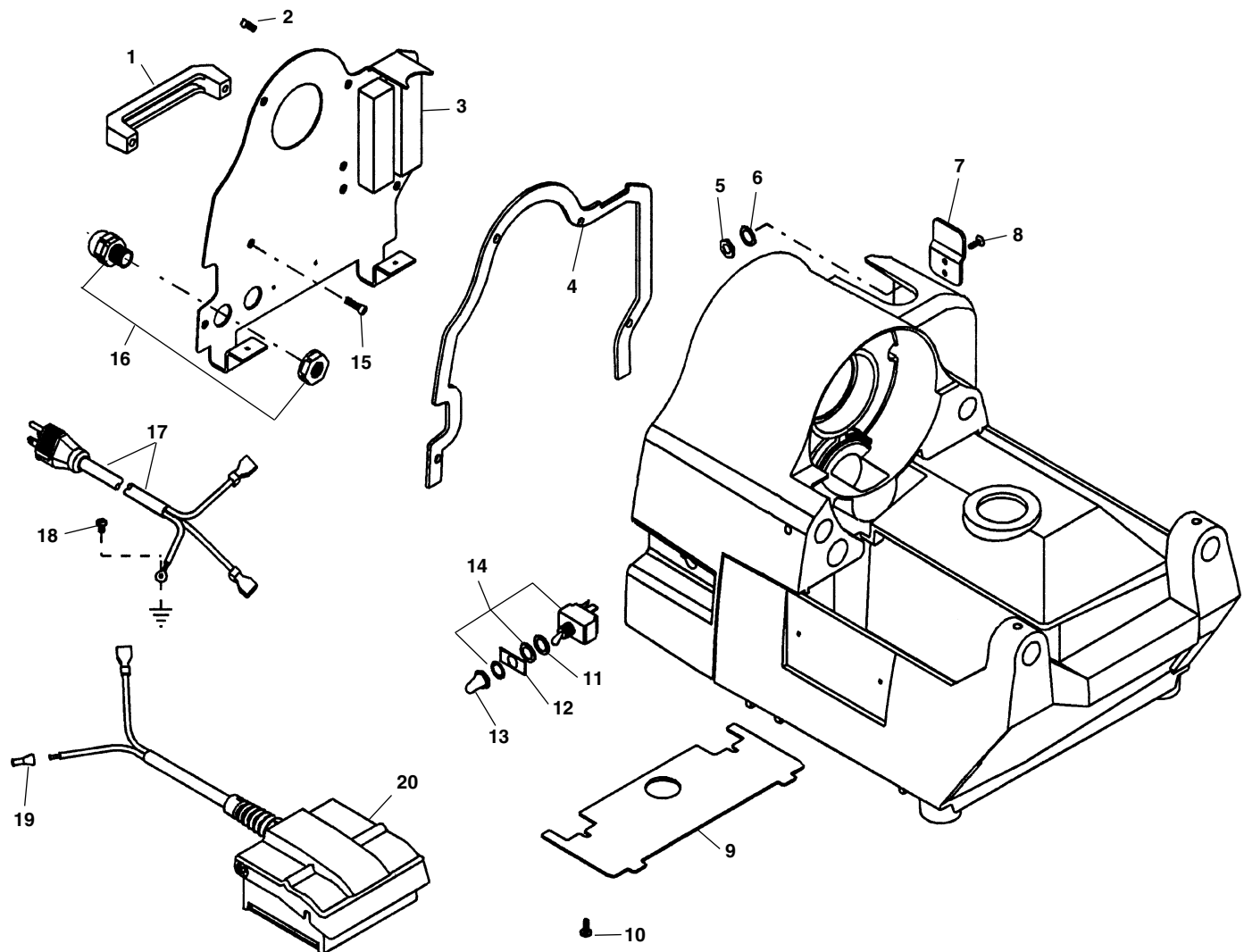

**NOTE: Order parts by Catalog Number only.  
DO NOT order by Reference Number.**

Ref. No.	Catalog No.	Description	Ref. No.	Catalog No.	Description
1	69342	Handle	11	23512	Rubber Washer
2	69192	Screw 1/4" - 20 x 1/2" Button Head (5)	12	69457	Switch Plate
3	69357	Rear Cover	13	23507	Switch Boot
4	69372	Rear Cover Gasket	14	69382	Switch
5	34722	Lock Nut #10-32 (2)	15	32145	Screw 1/4" - 20 x 1 1/2" Soc. Head (2)
6	58542	Lock Washer #10 (2)	16	69107	Strain Relief (2)
7	69377	Foot Switch Hook	17	69327	Power Cord 115V
8	35217	Screw #10-32 x 1/2" Button Head (2)	18	45420	Ground Screw
9	69287	Bottom Cover	19	44635	Wire Nut
10	45420	Screw #10-24 x 3/8" Pan Head (2)	20	69087	B-292 Foot Switch Assembly

**B-292 Foot Switch**

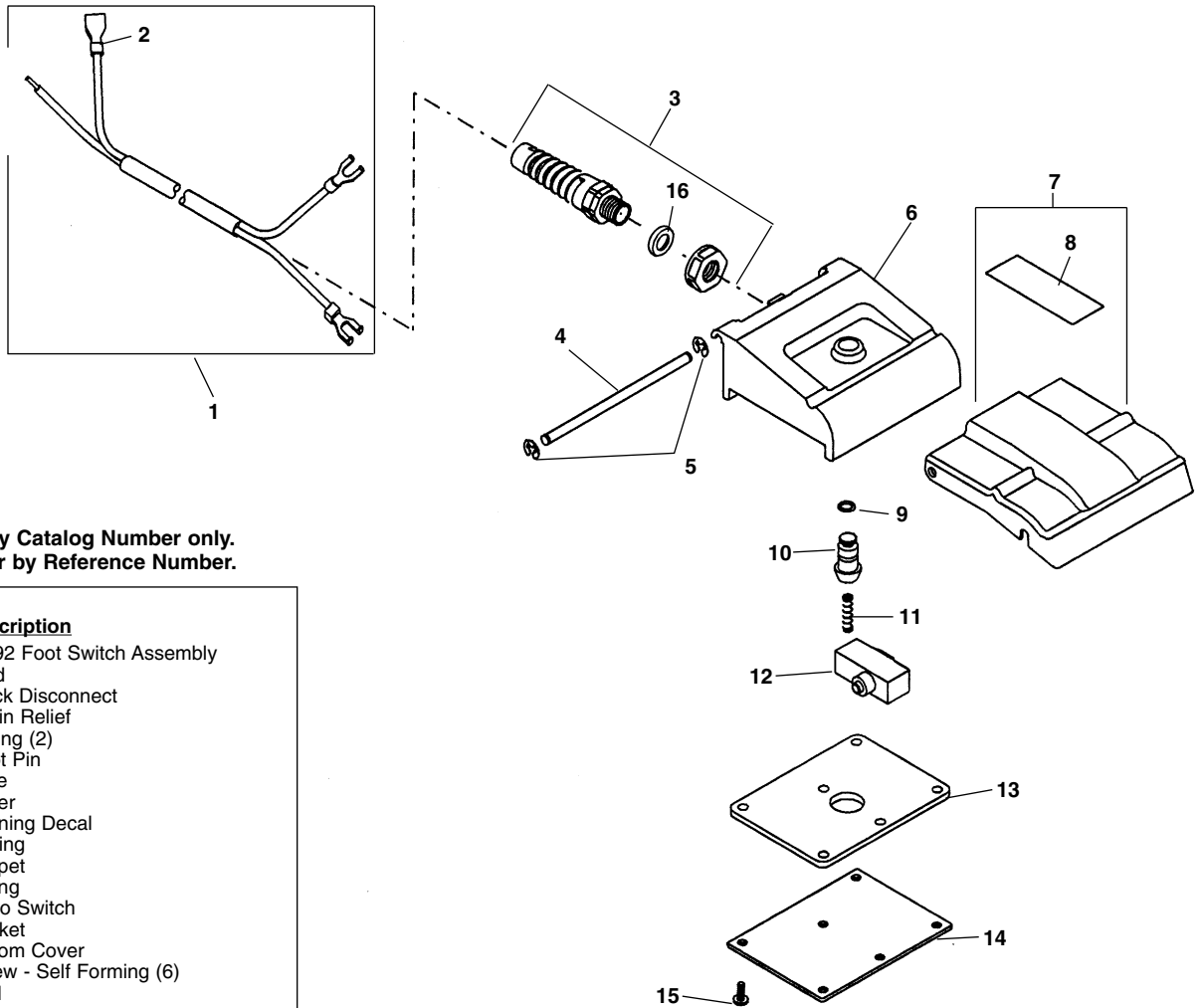

**NOTE: Order parts by Catalog Number only.  
DO NOT order by Reference Number.**

Ref. No.	Catalog No.	Description
—	69087	B-292 Foot Switch Assembly
1	69112	Cord
2	89190	Quick Disconnect
3	90402	Strain Relief
4	78780	E-Ring (2)
5	69117	Pivot Pin
6	69092	Base
7	69097	Cover
8	72432	Warning Decal
9	36767	O-Ring
10	69102	Poppet
11	69127	Spring
12	36762	Micro Switch
13	69137	Gasket
14	69122	Bottom Cover
15	69132	Screw - Self Forming (6)
16	90397	Seal

**Motor**

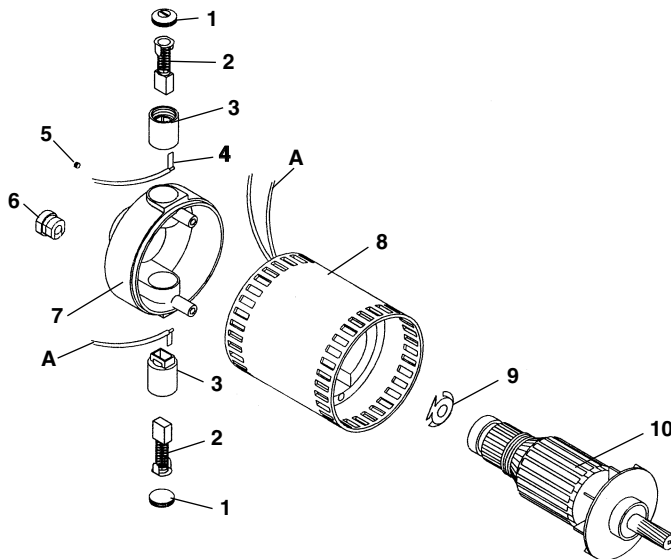

Ref. No.	Catalog No.	Description
—	69222	Motor 115V
1	60467	Brush Cap (2)
2	60472	Brush (2)
3	60482	Brush Holder (2)
4	69462	Brush Lead - Black
5	60492	Set Screw
6	69467	Cord Retainer
7	60522	End Bell
8	69467	Brush Lead - Red
9	69472	Field Assembly 115V
10	60512	Load Spring
11	69477	Armature 115V

120 Stand

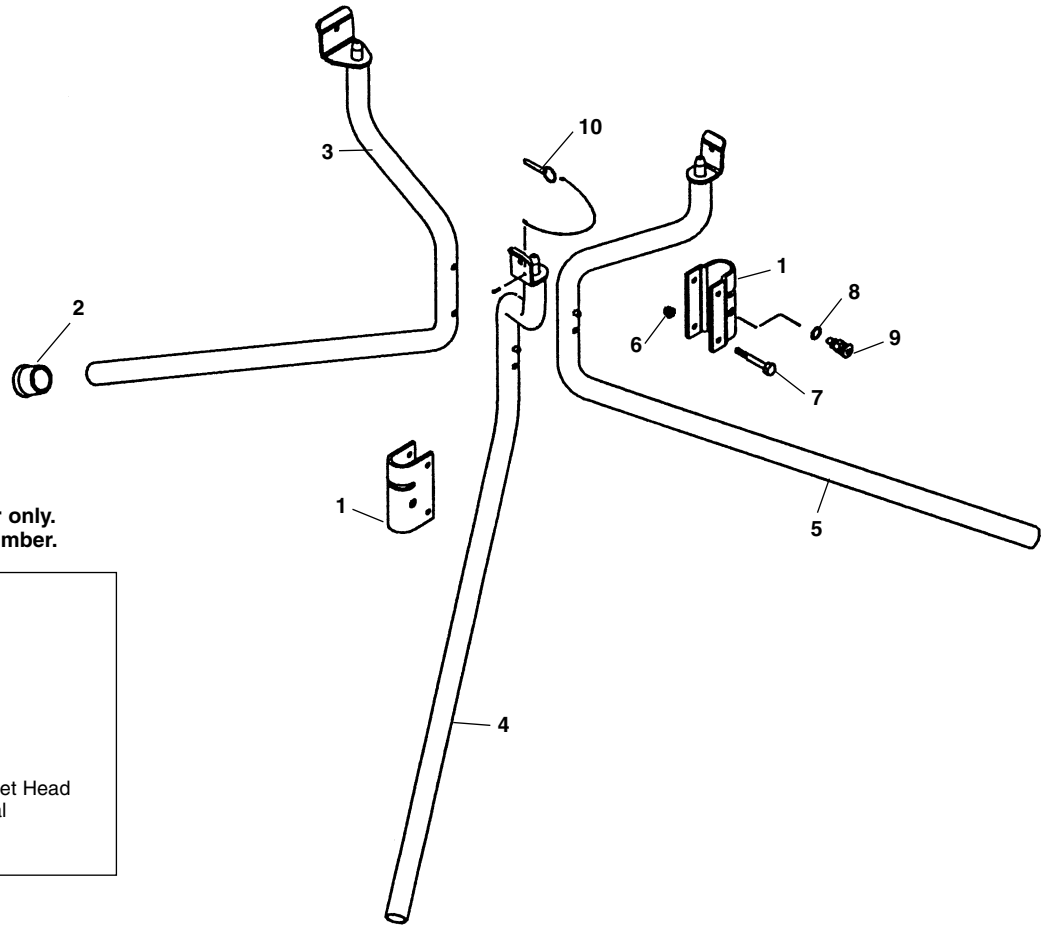

**NOTE: Order parts by Catalog Number only.  
DO NOT order by Reference Number.**

Ref. No.	Catalog No.	Description
—	67822	120 Stand
1	69422	Pivot Bracket Set
2	37962	Rubber Foot (3)
3	72287	Rear Leg
4	72292	Left Front Leg
5	72297	Right Front Leg
6	83890	Lock Nut 1/4" - 20
7	44510	Screw 1/4" - 20 x 2" Socket Head
8	75695	Lock Washer 7/16" Internal
9	59510	Plunger Assembly (2)
10	51092	Hitch Pin

120V 60 Hz

