

**No. 458**

Capacity: 1/8" through 3/4" (45°)

**No. 458MM**

Capacity: 4 mm through 16 mm (45°)

**No. 377**

Capacity: 3/16" through 3/4" (37°)

**NOTE: Order parts by Catalog Number only.  
DO NOT order by Reference Number.**

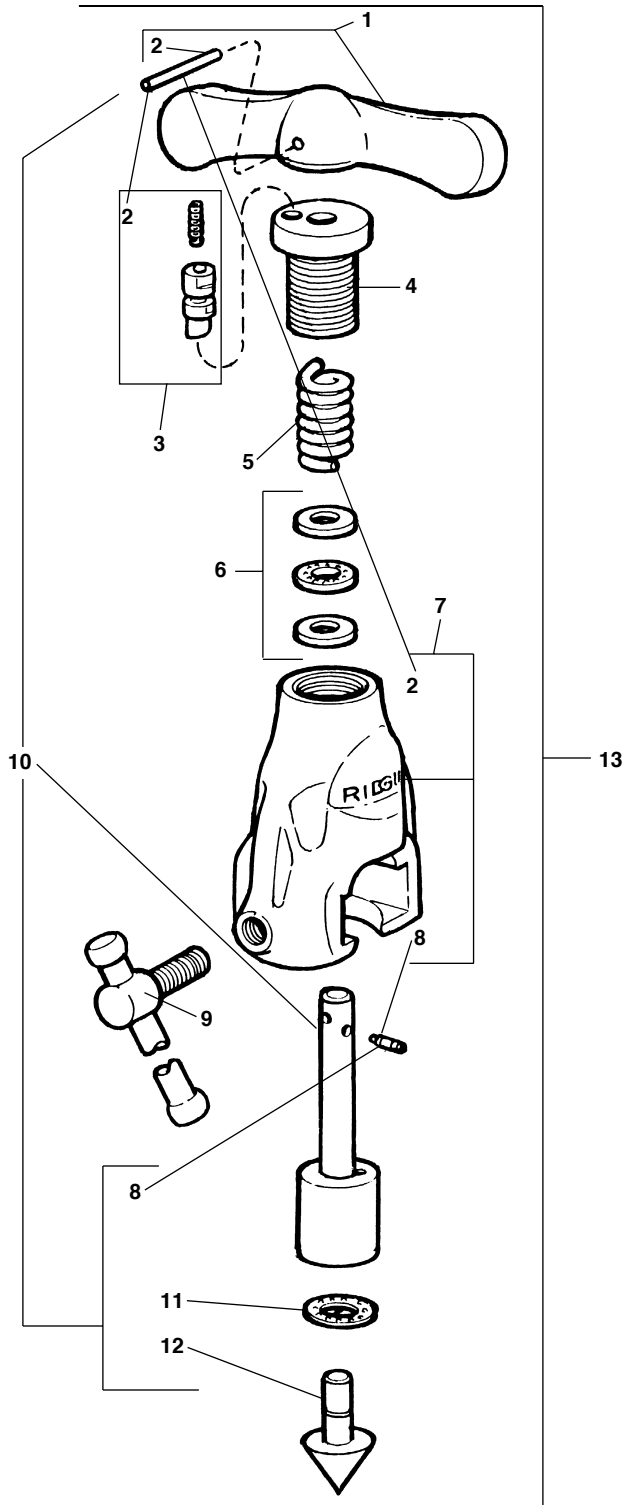

Ref. No.	Catalog No.	Description
1	41495	Handle with Pin
2	41500	Roll Pin
3	41510	Plunger Assembly
4	41525	Feed Screw - 45°
	41490	Feed Screw - 37°
5	41485	Spring
6	41520	Bearing Assembly
7	39722	Yoke Assembly
8	41505	Pin
9	41515	Clamp Screw Assembly
10	41475	Shaft Assembly - 45°
	41480	Shaft Assembly - 37°
11	41470	Thrust Bearing
12	41460	Cone - 45°
	41465	Cone - 37°
13	39742	Yoke and Shaft Assembly - 45°
	42092	Yoke and Shaft Assembly - 37°
14	41450	Stop Pin 2
15	41455	Locating Pin
16	39727	Flaring Bar Assembly - 458
	50267	Flaring Bar Assembly - 458mm
	42102	Flaring Bar Assembly - 377

