

RIDGID Water Pressure Tank

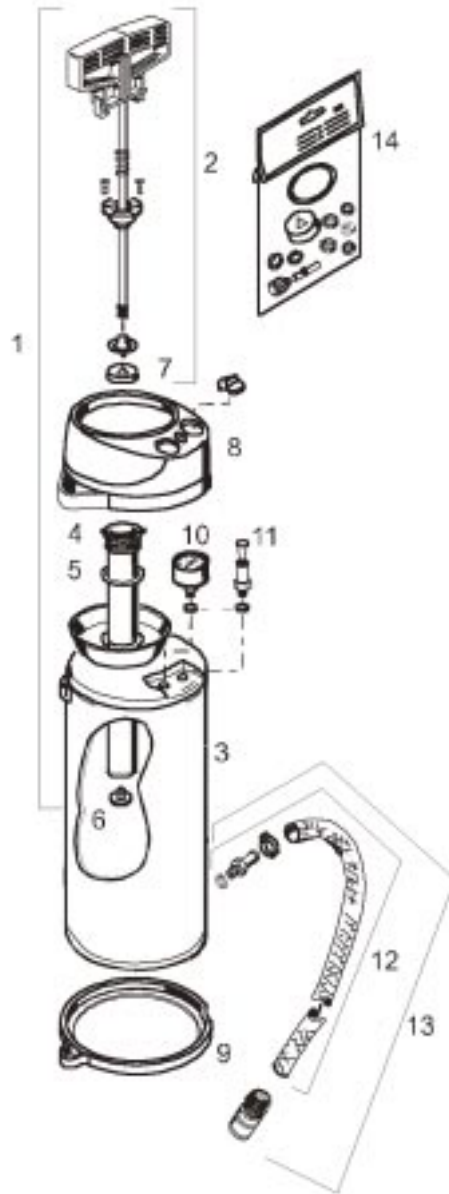

Ref. No.	Description	Cat.No.	Ref. No.	Description	Cat.No.
1	BRASS AIR PUMP	82206	13	HOSE 10 mm, 2,5 m incl. conn.	82326
2	PISTON ROD ASSY	82216	14	SEAL / SERVICE KIT containing nos.	82336
3	TANK 10 L	82226		Gasket D 14 x D 9,7 x 2 mm	
4	CYLINDER TUBE	82236		O-ring 10 x 3	
5	O-RING 42 x 4 mm	82246		Gasket D 15 x D 11 x 2 mm	
6	VALE DISC	82256		Gasket D 17 x D 8 x 2,3 mm	
7	PISTON WASHER	82266		Valve disc NBR	
8	TANK COVER	82276		O-ring D 17 x 2,5 mm	
9	FOOT RING	82286		O-ring D 42 x 4 mm	
10	PRESSURE GAUGE 6 bar	82296		Piston washer 38 mm	
11	SAFETY VALVE 6 bar	82306		O-ring D 4,42 x D 2,62	
12	HOSE 10 mm, 2,5 m	82316		O-ring D 3 x 1,5	