

RIDGID Tubing Cutters

No. 101 Tubing Cutter

NOTE: Order parts by Catalog Number only.
DO NOT order by Reference Number.

Ref. No.	Catalog No.	Description
1	42312	Wheel Housing
2	33970	Cutter Wheel Pin and Clip (Incl. Ref. No. 13)
3	33185	E3469 Cutter Wheel
4	33955	Stop Pin
5	34640	Roll (2)
6	42342	Roller Pin (2)
7	34750	Screw w/Washer
8	42337	Knob
9	42327	Retaining Ring
10	42322	Feed Screw
11	42332	Thrust Washer
12	42317	Roll Housing
13	74740	Clip

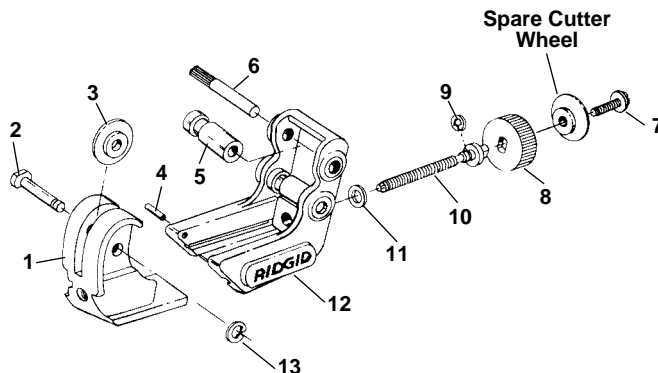

No. 103

Capacity: to 5/8" O.D.

No. 104

Capacity: to 15/16" O.D.

Ref. No.	Description	No. 103	No. 104
		Catalog No.	Catalog No.
1	Wheel Housing	47342	47332
*	Wheel Housing (Early Style)	33940	33985
2	Cutter Wheel Pin & Clip (Incl. Ref. No. 11)	33970	33970
3	Cutter Wheel	33185	33185
4	Stop Pin	33955	33955
5	Roll (2)	33965	33965
6	Roll Pin (2)	33960	33960
7	Retaining Ring	42327	42327
*	Retaining Ring (Early Style)	33830	33830
8	Feed Screw and Knob Assy.	47322	47317
*	Feed Screw and Knob Assy. (Early Style)	33945	33980
9	Washer	42332	42332
*	Washer (Early Style)	33950	33950
10	Roll Housing	47337	47327
*	Roll Housing (Early Style)	33935	33975
11	Clip	74740	74740

*Early style housings have plated finish

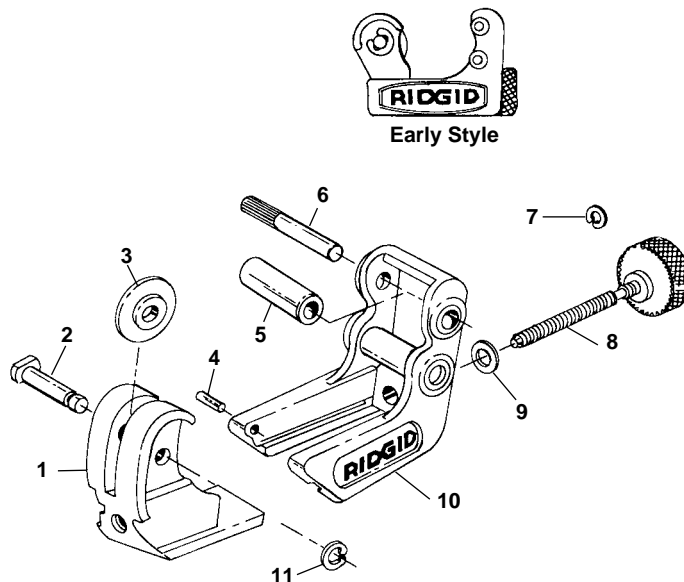

No. 105 and 150

Capacity: 1/8" through 1 1/8" O.D.

Ref. No.	Description	No. 105	No. 150
		Catalog No.	Catalog No.
1	Frame Assembly	33585	33127
2	Pin and Clip	33800	33800
3	Clip	74740	74740
4	Roll Pin (2)	34355	33142
5	Feed Screw	34630	33132
6	Slide Bar	34635	33137
7	Roll (2)	34640	34640
8	Bearing Cap	34645	34645
9	Reamer Blade Kit	34650	34650
10	Cutter Wheel (Thin)	33185	33185
11	Knob Assembly	34740	33177
12	Cutter Wheel (H. Duty)	33190	33190
13	Screw	34750	34750
14	Solid Roll (Special)	34765	34765

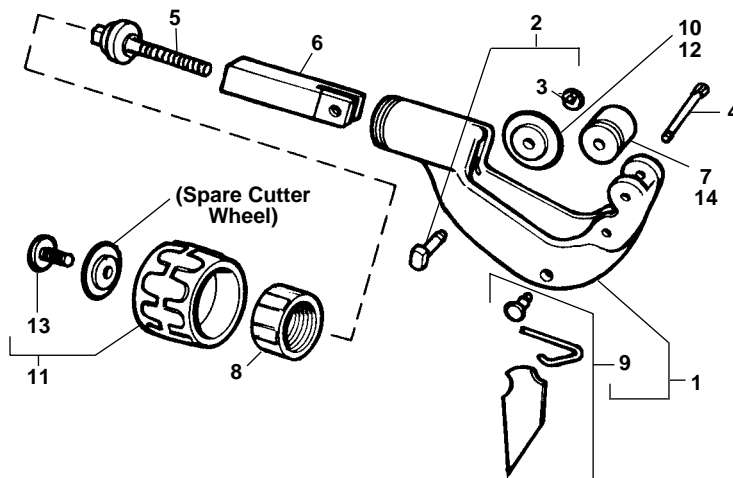

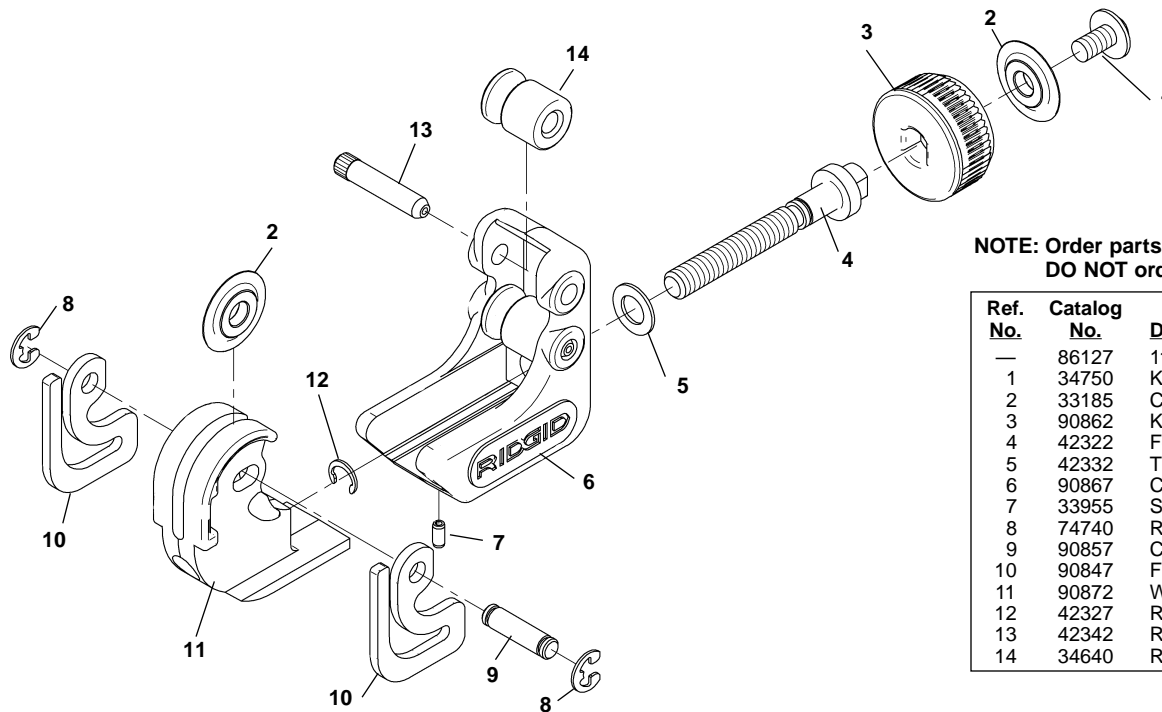

**NOTE: Order parts by Catalog Number only.
DO NOT order by Reference Number.**

Ref. No.	Catalog No.	Description
—	86127	118 Tubing Cutter
1	34750	Knob Retaining Screw
2	33185	Cutter Wheel (2)
3	90862	Knob
4	42322	Feed Screw
5	42332	Thrust Washer
6	90867	Cutter Frame
7	33955	Stop Pin
8	74740	Retaining Ring
9	90857	Cutter Wheel Pin
10	90847	Flat Spring (2)
11	90872	Wheel Housing
12	42327	Retaining Ring
13	42342	Roller Pin(2)
14	34640	Roller (2)

RIDGID Tubing Cutter

117

**NOTE: Order parts by Catalog Number only.
DO NOT order by Reference Number.**

Ref. No.	Catalog No.	Description
—	97787	117 Tubing Cutter
1	15348	Feedscrew Assembly
2	42332	Thrust Washer
3	33965	Roll (2)
4	42327	Retaining Clip
5	33185	Cutter Wheel
6	15358	Cutter Wheel Pin w/Clip
7	15363	Spring (2)
8	15368	Cutter Wheel Housing
9	33955	Roll Pin
10	74740	Retaining Clip
11	15353	Frame
12	33960	Pin (2)

