

Main Components

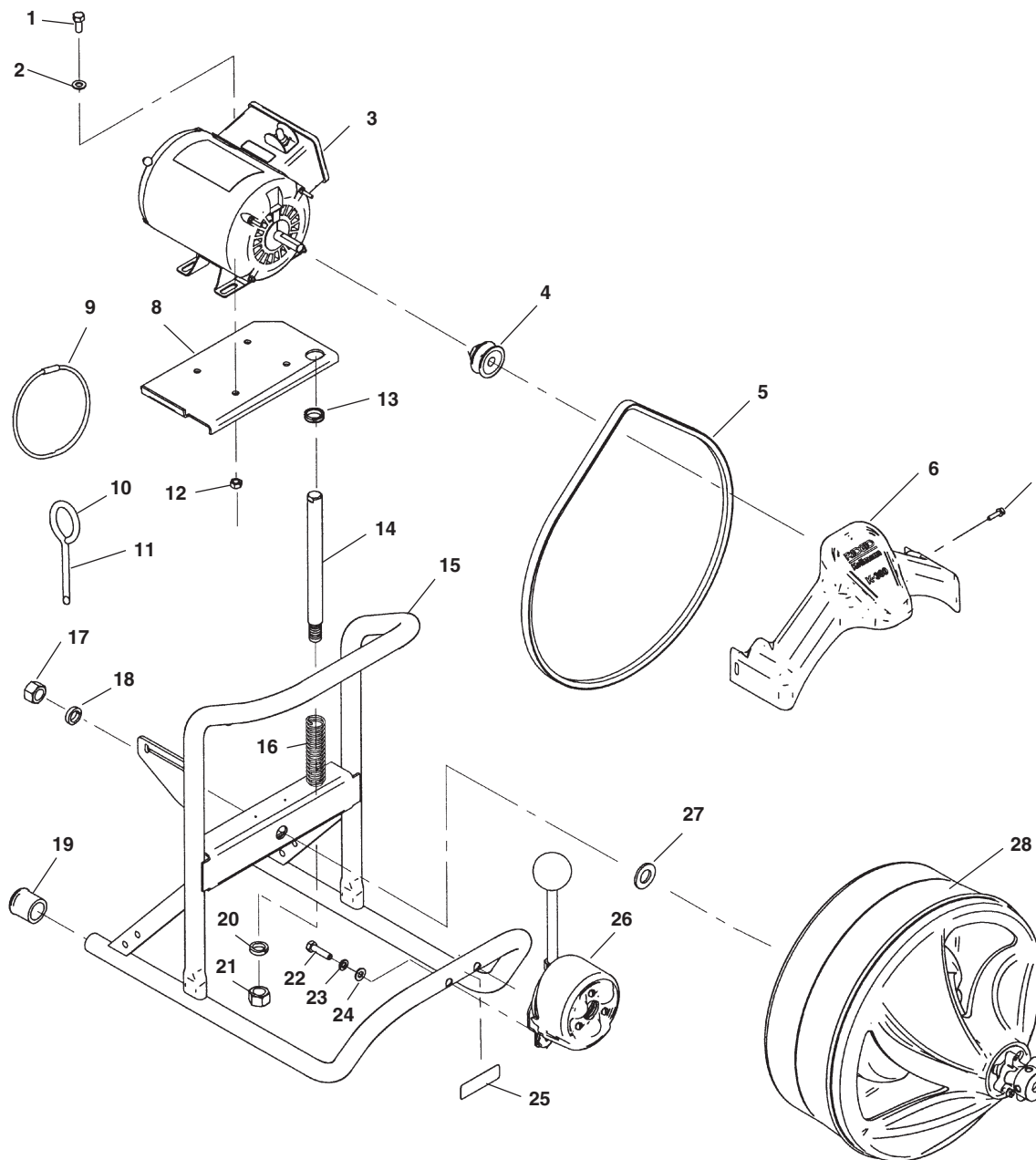

**NOTE: Order parts by Catalog Number Only.
DO NOT order by Reference Number.**

Ref. No.	Catalog No.	Description	Ref. No.	Catalog No.	Description
1	61130	Hex Screw 5/16" - 18 (4)	15	87007	K-380 Frame
2	60060	Flat Washer (4)	16	87002	Compression Spring
3	37977	Motor 115V	17	13617	5/8" - 11 Nut
4	86987	Pulley w/Set Screw	18	46682	5/8" Lockwasher
5	86977	Belt	19	37962	Rubber Tip (2)
6	86982	Belt Guard	20	46682	5/8" Lockwasher (2)
7	37907	#10 Screw (5)	21	13617	5/8" - 11 Nut (2)
8	86992	Motor Base Plate	22	60515	Hex Screw .31" - 18 x 1.25" (2)
9	54562	Tool Holder	23	60080	11/32" Lockwasher (2)
10	59230	3/8" Pin Key	24	60060	5/16" Flat Washer (6)
11	59225	1/2" Pin Key	25	87012	K-380 Label
12	27517	Lock Nut (4)	26	87337	K-380 Power Feed Assembly
13	37952	Split Grommet	27	41790	Flat Washer
14	86997	Spring Support Shaft	28	87077	K-380 Drum Assembly

Drum Assembly

NOTE: Order parts by Catalog Number Only. DO NOT order by Reference Number.

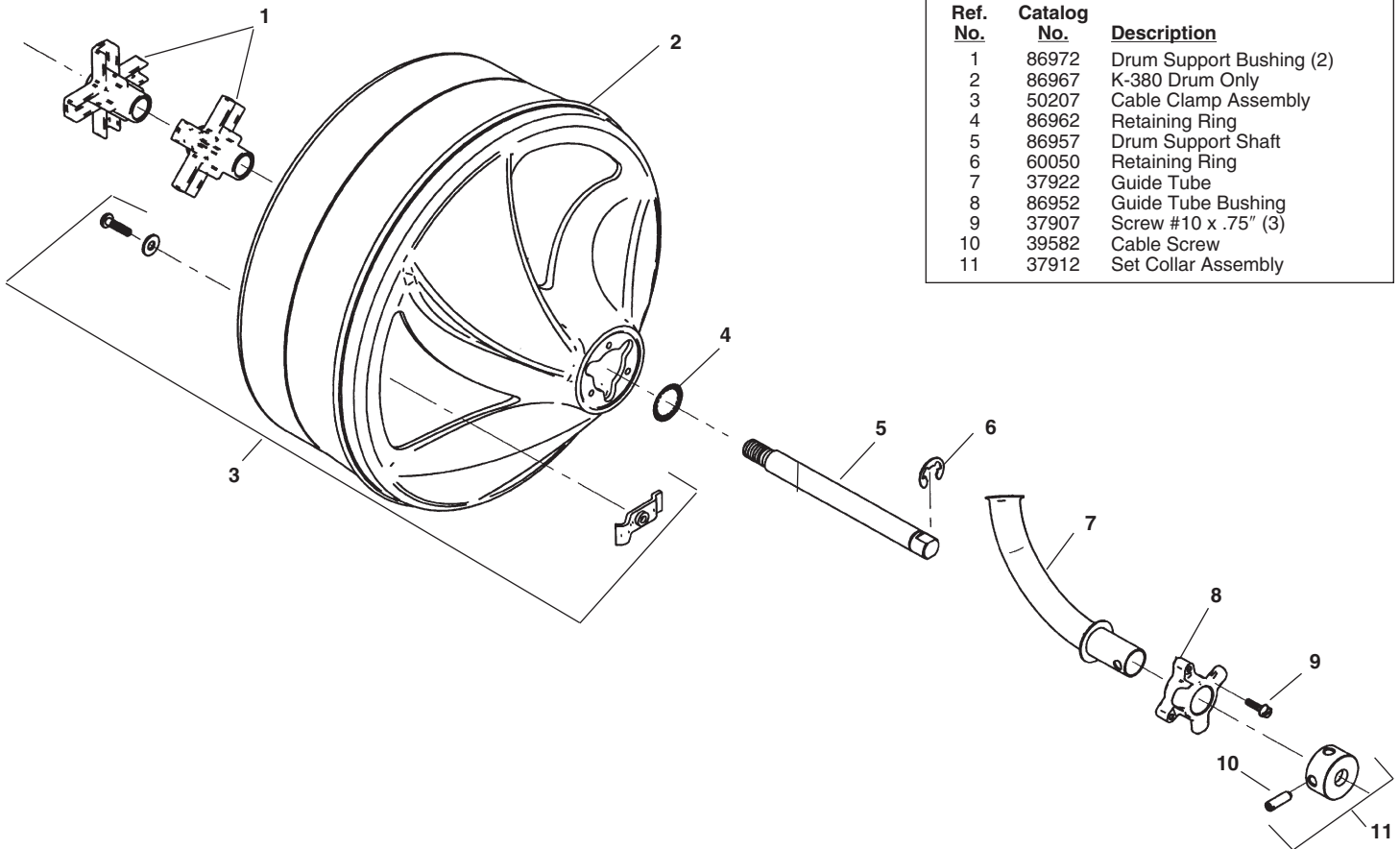

Ref. No.	Catalog No.	Description
1	86972	Drum Support Bushing (2)
2	86967	K-380 Drum Only
3	50207	Cable Clamp Assembly
4	86962	Retaining Ring
5	86957	Drum Support Shaft
6	60050	Retaining Ring
7	37922	Guide Tube
8	86952	Guide Tube Bushing
9	37907	Screw #10 x .75" (3)
10	39582	Cable Screw
11	37912	Set Collar Assembly

Autofeed Assembly

Ref. No.	Catalog No.	Description
—	87337	Autofeed Assembly
1	87627	Mounting Bracket
2	87607	Roller Shaft (6)
3	87622	Back Plate
4	93630	Clutch Handle
5	59585	Ball for Handle
6	87617	Spring
7	44077	Ball Bearing (3)
8	41502	Set Screw 5/16" - 18 x 3/4" (3)
9	87612	Front Plate
10	87632	Autofeed Cover
11	45420	Screw 10 - 24 x 3/8" (3)

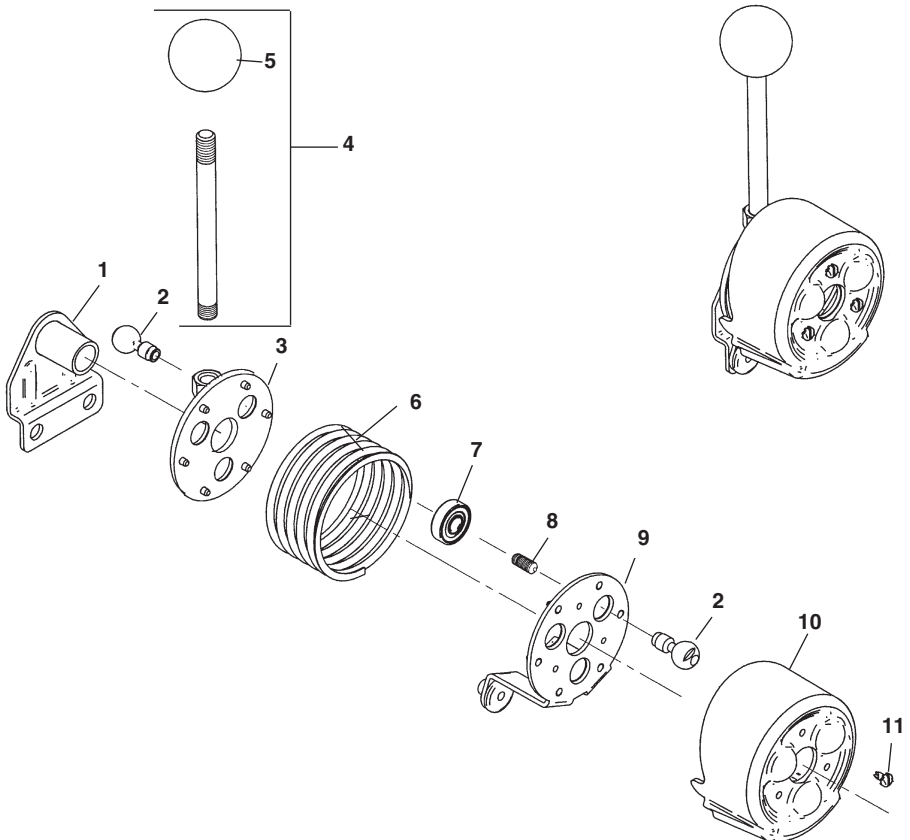

Electrical Components

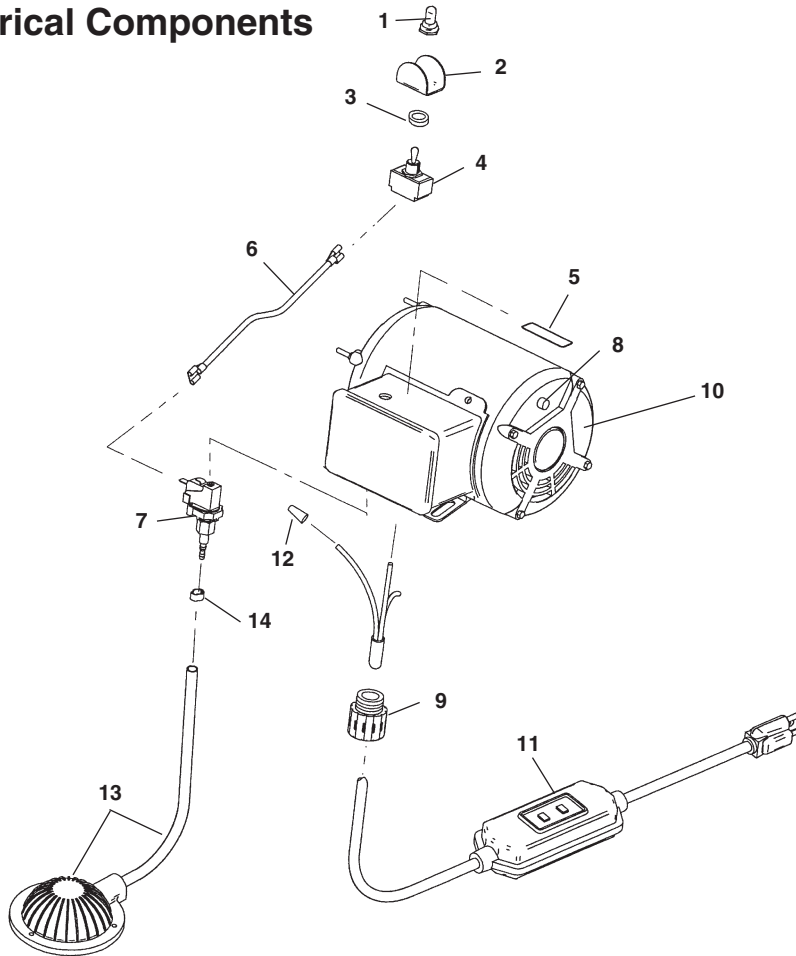

**NOTE: Order parts by Catalog Number Only.
DO NOT order by Reference Number.**

Ref. No.	Catalog No.	Description
1	23507	Rubber Boot
2	61490	Switch Guard
3	23512	Rubber Washer
4	41817	Switch
5	23687	FOR/REV Label
6	44877	Lead Wire Assembly
7	32992	Air Switch
8	67412	Thermal Overload
9	96265	Strain Relief
10	37977	120V 60Hz Motor Assembly (Includes Ref. No. 1 - 9)
	44702	220/240V 50Hz Motor Assy. (Includes Ref. No. 1-9)
11	50507	120V Power Cord w/GFCI
	15707	220V Power Cord
12	44635	Wire Nut
13	37967	Foot Switch Assembly
14	35142	Hose Clamp

Wiring Diagram

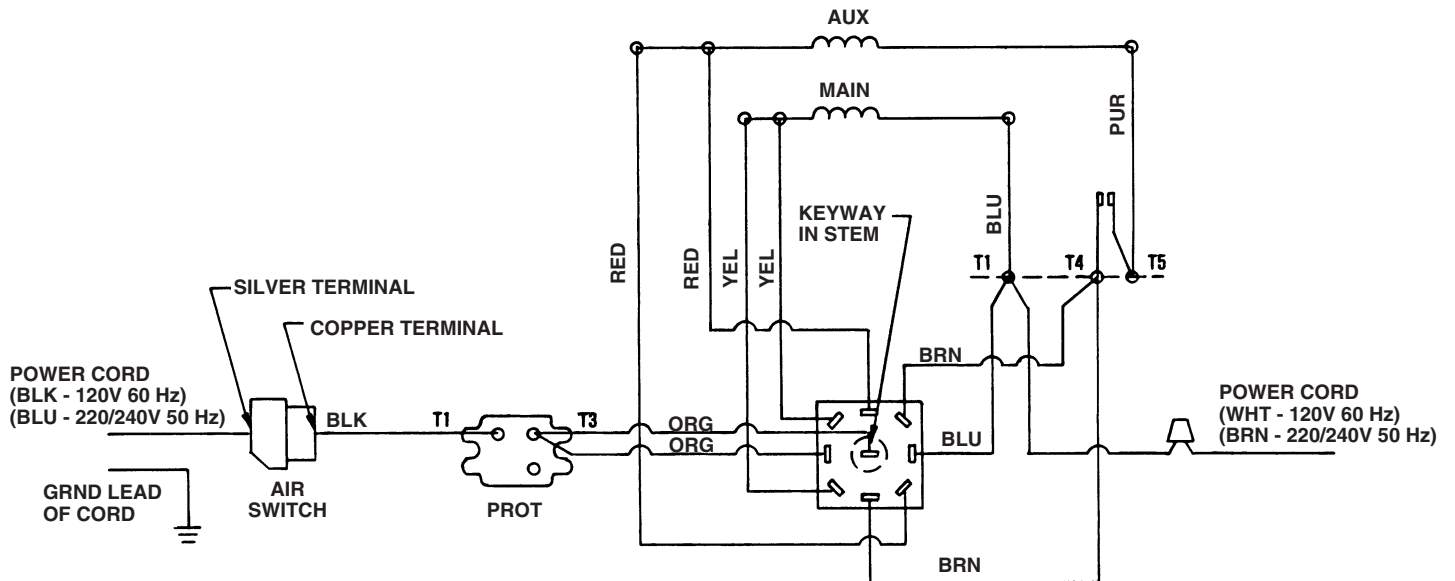

Electrical Components Europe & Australia

NOTE: Order parts by Catalog Number Only.
DO NOT order by Reference Number.

Ref. No.	Catalog No.	Description
1	44882	Jumper Wire Assembly
2	44862	Switch
3	23687	FOR/REV Label
4	44877	Lead Wire Assembly
5	32992	Air Switch
6	35142	Hose Clamp
7	37967	Foot Switch Assembly
8	44635	Wire Nut
9	27187	Strain Relief
10	44712	110/220/240V 50Hz Motor Assy.
11	39562	220V Power Cord (Europe)
	44512	240V Power Cord (Australia)
12	67417	Thermal Overload

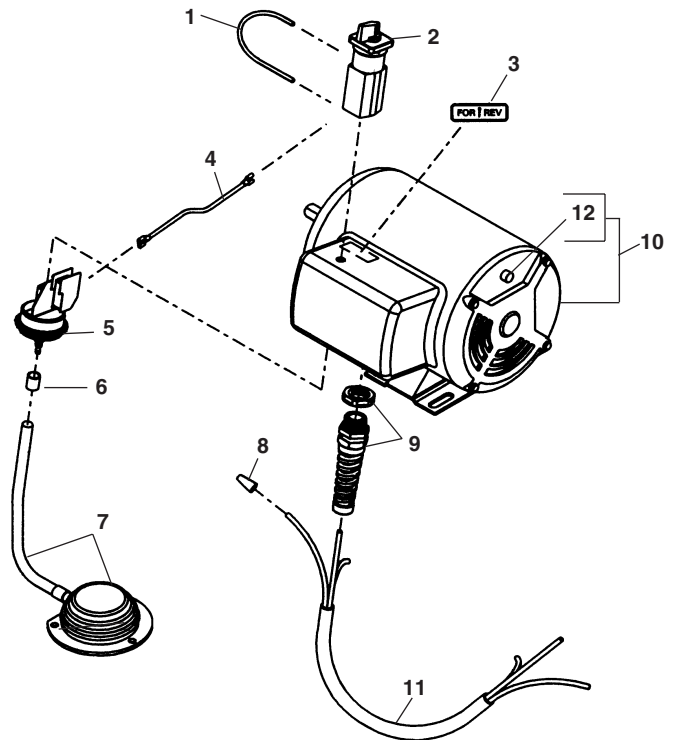

220/240V 50Hz Wiring Diagram

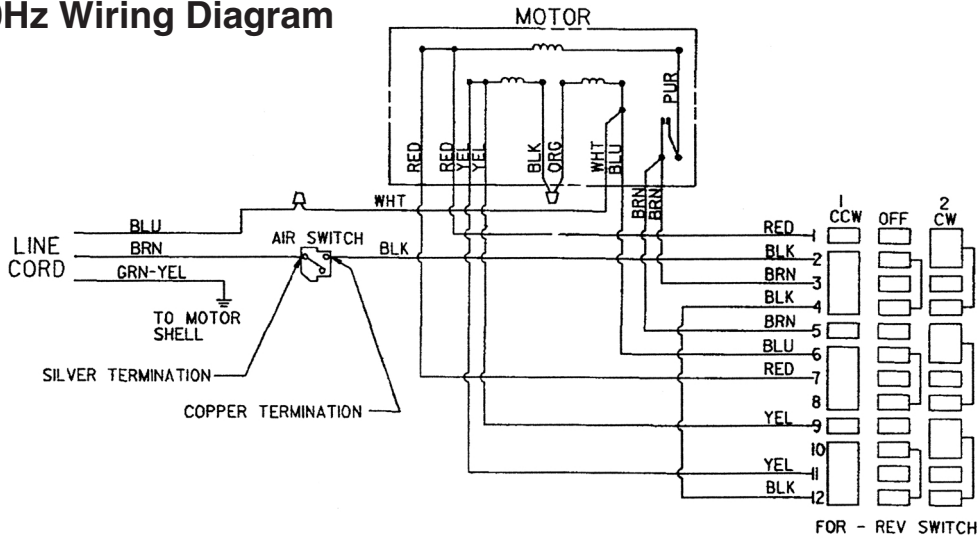

110V 50Hz Wiring Diagram

